



Customs Laboratories  
European Network

## **ILIADe 606:2024| CLEN Method**

**Determination of n-Butylphenyl Ether (BPE) in gas oil, kerosene  
and tax-privileged petroleum products by two-dimensional  
gas chromatography with mass-selective detector**

**Version 13 February 2024**

**adopted as CLEN method  
at the 26<sup>th</sup> CLEN Plenary Meeting on 13 February 2024**

# Determination of n-Butylphenyl Ether (BPE) in gas oil, kerosene and tax-privileged petroleum products by two-dimensional gas chromatography with mass-selective detector

## 1. Scope and field of application

### 1.1 Introduction and references

In the Commission Implementing Decision (EU) 2022/197 of 17 January 2022 a common fiscal marker (ACCUTRACE™ Plus) for gas oils and kerosene has been established. For the proper functioning of the internal market and in particular to prevent tax evasion, Council Directive 95/60/EC of 27 November 1995 has provided for a common marking system to identify gas oils and kerosene, which are subject to a reduced excise duty rate.

This publication provides a method for the determination of the active ingredient n-butylphenyl ether (BPE, butoxybenzene) of ACCUTRACE™ Plus in gas oil and kerosene. It shall be applied for the examination of marked low tax mineral oils and mixtures with diesel.

The marker is:

ACCUTRACE™ Plus consisting of approximately 24 % naphthenic hydrocarbons as solvent and 76 % BPE (CAS #1126-79-0, EC# 214-426-1).

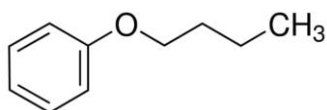

Figure 1. Structure of BPE

Member States shall set a marking level of ACCUTRACE™ Plus at least 12.5 milligram per litre and not more than 18.75 milligram per litre of energy product. This corresponds to a marking level at least 9.5 milligram of BPE per litre and not more than 14.25 milligram of BPE per litre of energy product.

### 1.2 Scope

This method describes the analysis of BPE (section 3.3), in the linear concentration range from the detection limit to approximately 20 mg per litre in gas oil and kerosene.

## 2. Principle

BPE is quantified by two-dimensional gas chromatography coupled with a mass-selective detector (MSD). For this purpose, the sample is injected into the carrier gas flow and is gas chromatographically pre-separated on a first, non-polar column and detected by flame ionisation detection (FID). At the time of the expected elution of BPE, a part of the eluent is diverted onto a second, more polar column (so-called heart-cut) and BPE is detected and quantified by mass spectrometry at  $m/z = 94$  and  $150$  (SIM mode). After the heart cut, the carrier gas flow might be reversed and high boiling components are discharged through the injector (so-called backflush). Figure 2 shows a scheme of the 2D-heart-cut system used in the determination of BPE in fuels.

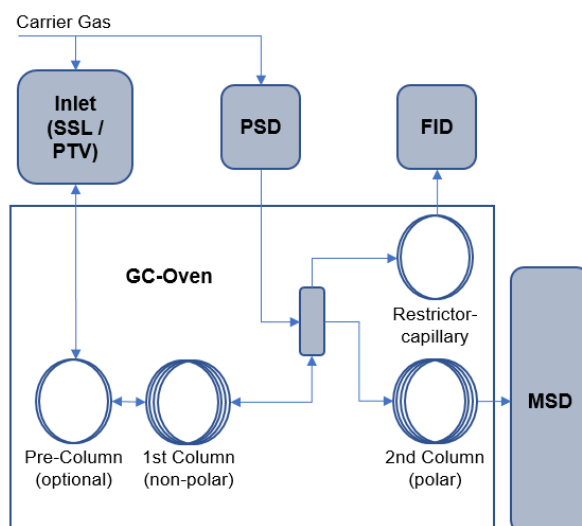

Figure 2. Scheme of 2D heart-cut GC-MS-System used for the detection of BPE in fuels.

In general, the method can be used in two versions:

PROCEDURE A) undiluted sample injection and quantification using external standard; and  
 PROCEDURE B) by aliquot dilution with an internal standard solution (ISTD).

The ISTD is a deuterated BPE (d5-BPE, section 3.4) at the phenyl ring. The advantage of the added ISTD is to compensate for precision-reducing factors such as fluctuations in injection volume and decreasing sensitivity. On the other hand, the samples must be diluted before analysis when using the ISTD.

### 3. Reagents and materials

- 3.1 Toluene (for Chromatography, purity  $\geq 99.9\%$ )
- 3.2 Xylene-Isomeric mixture or *o*-Xylene (for Chromatography, purity  $\geq 98\%$ )
- 3.3 BPE (purity  $\geq 99\%$ )
- 3.4 d5-BPE (purity  $\geq 98\%$ ) or commercially available d5-BPE solution of known concentration
- 3.5 Diesel fuel with and without biodiesel (e.g. Diesel-B0 and Diesel-B7)

All reagents should be handled and stored according to their safety instructions.

### 4. Apparatus and instrumental settings

- 4.1 Gas chromatograph with autosampler, split-splitless-inlet (SSL) or temperature programmable inlet (PTV), Pneumatic Switching Device (PSD), FID and MSD with ion-extractor or comparable electron impact ionisation source.
- 4.2 Personal computing system with software for data acquisition and analysis.
- 4.3 Standard laboratory glassware.
- 4.4 Analytical balance (at least 4-digits).
- 4.5 Water bath (Thermostat at  $20 \pm 0.2\text{ }^{\circ}\text{C}$ ).
- 4.6 Micropipettes (for the preparation of standards and the isotopic dilution with ISTD).
- 4.7 PTFE-Syringe Filters (e.g. Pore Size  $0,2\text{ }\mu\text{m}$ , Diameter 25 mm)
- 4.8 Chromatographic conditions

The following **indicative conditions** have been successfully tested. Each laboratory has to optimize the method parameters according to its own instrumental equipment.

Calculate the appropriate pressure and flow values using a PSD calculation tool.

Particular attention must be paid to the length of the heart cut timing event (on-off valve of the PSD). Verify at least monthly the Heart Cut parameters and certainly after any change of the equipment by injecting a solution of BPE at the level of the highest standard concentration in xylene or toluene.

A shift of the BPE retention time or a deterioration of the peak shape (e.g. tailing) in the first column would reduce the amount of analyte sent to the second column, leading to an underestimation of BPE concentration if the timing of the PSD is not modified accordingly.

**Hydrogen may be used as carrier gas instead of Helium.**

Device	Parameter	Value for SSL-Inlet	Value for PTV- or SSL-Inlet
Autosampler	Injection volume:	1 µl (10 µl Syringe) with 0.2 µl Air gap	0.2 µl (1 µl Syringe) with 0.02 µl Air gap
	Solvent Washes:	2 times 8 µl before and 5 times 4 µl after Injection	2 times 0.8 µl before and 5 times 0.4 µl after Injection
	Sample Washes:	2 times with 2 µl sample	2 times with 0.4 µl sample
	Wash Solvent:	Toluene	
	Viscosity Delay:	2 s	
	Plunger Draw Speed:	Solvent 300 µl / min; Sample 100 µl / min	
	Dispense Speed:	3000 µl / min	
	Injection Speed:	6000 µl / min	
Inlet	Liner:	Ultra-inert (900 µl, split/splitless, single taper, glass wool)	
	Temperature:	250 °C or 300 °C	300 °C and up to 400 °C after Heart Cut (PTV)
	Split:	50 : 1 (with ISTD), 100 : 1 (without ISTD)	5 : 1 (with ISTD), 10 : 1 (without ISTD)
		Split adjustment related to dilution with ISTD.	
	Carrier Gas:	Helium (104 ml / min, Split 1 : 100 , Gas Saver after 3 min) Helium (14 ml / min, Split 1 : 10 , Gas Saver after 3 min)	
	Septum Purge:	3 ml / min	

Device	Parameter	Setup 1 (SSL-Inlet and Backflush)	Setup 2 (SSL- or PTV-Inlet with or without Backflush)
Capillary Columns	Pre Column:	none	e.g. deactivated guard column (L: 5 m, ID: 0,25 mm)
	1. Column:	Capillary with nonpolar phase, e.g. DB-17HT (L: 15 m, ID: 0.25 mm, Film 0,15 µm)	Capillary with nonpolar phase, e.g. DB-1HT (L: 15m, ID: 0.25 mm, Film 0.1 µm);
	2. Restrictor to FID:	e.g. empty Capillary (L: 0.64 m, ID: 0.1 mm)	e.g. empty Capillary (L: 0.68 m, ID: 0.1 mm)
	3. Column:	Capillary with polar phase, e.g. VF-WAXms (L: 30 m, ID: 0.25 mm, Film 1.0 µm).	Capillary with polar phase, e.g. SLB-IL60 (L: 30 m, ID: 0.25 mm, Film 0.2 µm).
Column Flow Rates	1. Column:	1 ml / min for 5.15 min, then -1 ml / min until 15.167 min (Backflush)	1.075 ml / min for 4.3 min, then -3 ml / min until 15 min (in case of Back Flush)
	2. Restrictor to FID:	2.5 ml/min	2.5 ml/min
	3. Column	Flow Control via 2. Column (2.34 ml / min).	Flow Control via 2. Column (2.48 ml / min)
Column oven		100 °C for 0.5 min, 10 °C / min to 180 °C, 30 °C / min to 260°C, 260 °C hold 4 min; Total Run Time: 15.167 min	100 °C for 1 min, 5 °C / min to 125 °C, 100 °C / min to 260°C, 260 °C hold 7.65 min; Total Run Time: 15 min <b>or without Backflush:</b> 100 °C for 1 min, 5 °C / min to 125 °C, 100 °C / min to 260°C, 260 °C hold 3 min, 10 °C / min to 290 °C, 290 °C hold 6.65 min; Total Run Time: 20 min
PSD / Heart Cut	Valve on:	4.94 min	4.00 min
	Valve off:	5.07 min	4.20 min
	Determined and regularly verified with BPE solution at the level of the highest standard concentration in Xylene or Toluene.		
FID	Temperature:	285 °C	
	Air Flow:	400 ml / min	
	H <sub>2</sub> -Flow:	40 ml / min	
	Makeup (N <sub>2</sub> )-Flow:	25 ml / min	
	Data Rate:	20 Hz	

Device	Parameter	Setup 1 (SSL-Inlet and Backflush)	Setup 2 (SSL or MMI with or without Backflush):
MSD	Transfer Line Temperature:	260 °C	
	El-Source Temperature:	230 °C	
	Quadrupole-Temperature:	150 °C	
	Gain Factor:	1.0	
	SIM Ions BPE:	m/z = 94 and 150 (Quantifier and Qualifier)	
	SIM Ions d5-BPE	m/z = 99 and 155 m/z (Quantifier and Qualifier)	
	Dwell-Time:	100 ms each	
	Scan Speed:	1.562 u / s	
	Solvent Delay:	8.0 min	6.1 min
	Detector off:	9.5 min	7.6 min

Table 1 Chromatographic Conditions

## 5. Procedure

### 5.1 General

Take a representative sample of the product to be analysed. For quantification, analyse the samples in duplicate. Sample filtration is only necessary if the samples appear to contain solid impurities. In this case, the use of PTFE syringe filters (4.7) is recommended.

### 5.2 Preliminary examination

In particular for high sample numbers, a preliminary examination is recommended to determine whether BPE is detectable in the samples at all. To this end, the samples can be measured undiluted without adding the ISTD and without calibration. In order to check whether the gas chromatographic system has sufficient sensitivity and separation performance, a control solution containing BPE in a gas oil matrix shall be injected before the samples. It is recommended to use approximately 0.5 % of the concentration required in marked light fuel oil (e.g. standard solution 9).

Test procedure:

Analyse standard solution 9 as it is (undiluted) as a control.

Analyse the sample as it is (undiluted).

If the control is successful and there is no signal for BPE in the sample, the sample can be considered negative and no further analysis is required.

Repeat the analysis of the control sample after 10 unknown samples.

### 5.3 PROCEDURE A): Determination without Internal Standard

#### 5.3.1 Sample preparation for quantification

Fill the samples in 2 ml vials and close them well.

#### 5.3.2 Control samples

Spike BPE-free diesel fuel with BPE to prepare two control samples at levels of approximately 10 mg/l and 0.1 mg/l. The preparation can be done as for standard solutions 2 and 8. Alternatively, a certified reference material (CRM) can be used.

#### 5.3.3 Standard solutions with BPE

##### 5.3.3.1 Stock solutions for standard preparation

Stock solution I: Weigh approximately 750 mg of BPE (with accuracy of 0.1 mg) into a 100-ml volumetric flask and fill to the mark with Diesel-B0 or Diesel-B7. This stock solution has a concentration of BPE of approximately 7500 mg/l.

**The purity of the calibration substance according to the certificate of analysis shall be considered.**

Stock solution II: Transfer 2000 µl of the stock solution I to a 100-ml volumetric flask and fill to the mark with Diesel-B0 or Diesel-B7. This stock solution has a concentration of BPE of approx. 150 mg/l.

Before final filling, bring the mixtures to 20 °C in the water bath (section 4.5) for at least 30 minutes.

**The weights, target concentrations and final volumes are indicative values. A uniform distribution of the concentrations of the standards across the working range must be ensured.**

##### 5.3.3.2 Standard solutions with BPE for calibration

The standard solutions can be prepared according to Table 1 from stock solutions described in section 5.3.3.1.

Standard-solution	Target concentration [mg / l]	Diluted from BPE-Stock- / Standard solution	Volume BPE-Stock- / Standard added [ml]	Total volume diluted to [ml]
<b>1</b>	<b>15.000</b>	<b>Stock solution II</b>	<b>10</b>	<b>100</b>
2	10.5000	Stock solution II	7	100
<b>3</b>	<b>7.5000</b>	<b>Stock solution II</b>	<b>5</b>	<b>100</b>
4	3.7500	Stock solution II	2,5	100
<b>5</b>	<b>1.0500</b>	<b>Standard solution 2</b>	<b>10</b>	<b>100</b>
<b>6</b>	<b>0.5250</b>	<b>Standard solution 2</b>	<b>5</b>	<b>100</b>
7	0.2100	Standard solution 2	2	100
<b>8</b>	<b>0.1050</b>	<b>Standard solution 5</b>	<b>10</b>	<b>100</b>
<b>9</b>	<b>0.0525</b>	<b>Standard solution 5</b>	<b>5</b>	<b>100</b>
10	0.0210	Standard solution 5	2	100

Table 2 Dilution series for the preparation of standard solutions

Before final filling, bring the mixtures to 20 °C in the water bath (section 4.5) for at least 30 minutes. The weights, target concentrations and final volumes are indicative values.

For routine calibration, the use of at least 6 calibration points (**bold printed**) is sufficient. The calibration solutions are injected prior to the samples. If necessary, multiple injections of the standards are possible.

The extension of the working area by additional standards with higher BPE concentrations is possible. In this case, it is necessary to check whether linear regression is allowed.

Calibration solutions should be tested / remixed at least once a year.

**The calibration curve is forced through zero.**

Common chromatograms are given in Annex 1.

#### 5.4 PROCEDURE B): Determination with Internal Standard

##### 5.4.1 Sample preparation for quantification

Dilute 800 µl of the standard solution, sample or control sample with 800 µl of the ISTD standard solution III (section 5.4.3) in a 2 ml GC vial using an automatic pipette with variable dosing speed. Close the vial and mix well.

Alternatively, the ISTD solution III can be added by a so called 2-layer-sandwich injection to the undiluted sample in the autosampler module of the GC, preferably by using a small overall injection volume and syringe.

If the samples visually contain solids and need to be filtered, this should be done with the original sample and not after the internal standard has been added.

##### 5.4.2 Control samples

See section 5.3.2

##### 5.4.3 Internal standard solution with d5-BPE in xylene

ISTD stock solution I: Weigh approximately 500 mg d5-BPE (with an accuracy of 0.1 mg) into a 100-ml volumetric flask and fill to the mark with xylene (3.2). This stock solution has a d5-BPE concentration of approximately 5000 mg/l.

**The purity of the calibration substance according to the certificate of analysis shall be taken into account.**

ISTD stock solution II: 1000 µl of the ISTD stock solution I is transferred to a 50-ml volumetric flask and filled to the mark with xylene (3.3). This stock solution has a d5-BPE concentration of approximately 100 mg/l.

ISTD stock solution III: 2000 µl of the ISTD stock solution II is transferred to a 100-ml flask and filled to the mark with xylene (3.2). This stock solution has a d5-BPE concentration of approximately 2 mg/l.

Before final filling, bring the mixtures to 20°C in the water bath (section 4.5) for at least 30 minutes.

Instead of self-prepared ISTD solutions, a commercially available concentrate can also be used after appropriate dilution.

##### 5.4.4 Standard solutions with BPE

See section 5.3.3.

For routine calibration, the use of at least 6 calibration solutions (**bold printed**) is sufficient. The calibration solutions are injected prior to the samples. If necessary, multiple injections of the standards are possible.

**The calibration curve is forced through zero.**

Common chromatograms are given in Annex 1.



## 5.5 Calibration procedure and calculation

In routine analysis, a 7-point linear calibration is performed (6 points and forced zero, see also 5.3.3.2 and 5.4.4).

### PROCEDURE A):

Construct the calibration curve by plotting the area of the quantifying ion ( $m/z = 94$ ) of the BPE peak in each standard chromatogram against the exact concentration of the respective standard in mg/l. Fit with a linear regression; force through zero.

Calculate the concentration  $X$  (mg/l) of BPE in the sample from the linear equation:

$$X = \frac{Y}{a}$$

where

$a$  = the slope of the regression line

$Y$  = the area of the quantifying ion of the BPE ( $m/z = 94$ ) in the sample's chromatogram

### PROCEDURE B):

Construct the calibration curve by plotting the ratio of the area of the quantifying ion ( $m/z = 94$ ) of the BPE peak to the area of the quantifying ion of the d5-BPE ( $m/z = 99$ ) peak in each standard chromatogram against the exact concentration of the respective standard in mg/l. Fit with linear regression; force through zero. Use the linear regression to determine the concentration of the sample in mg/l.

Calculate the concentration  $X$  (mg/l) of BPE in the sample from the linear equation:

$$X = \frac{Y'}{a}$$

where

$a$  = the slope of the regression line

$Y'$  = the ratio of the area of the quantifying ion of the BPE ( $m/z = 94$ ) to the area of the quantifying ion of the d5-BPE ( $m/z = 99$ ) peak in the sample's chromatogram

Perform the calibration regularly (at least every month) and after any instrument modification (e.g. MSD-tuning, change of liner, heart-cut modification) or in case of a quality control failure.

Quality control:

Analyze a blank toluene and the control samples (5.3.2) after each calibration. Repeat after measurement of 10 samples (in duplicate). Monitor the results in control charts. Repeat the calibration if the quality control fails or if there is a trend of more than 7 points.

**Proceed with the quantitative evaluation only if the signals from BPE and d5-BPE are not disturbed and the ratio of the molecular peak to the base peak is in the expected range (qualifier ion).**

## 6. Expression of results

Express the BPE content as a mass concentration in mg/l rounded on two decimals.

Determine the last digit according to DIN 1333.

## 7. Analytical Performance

### 7.1 Working Range and Linearity

Linearity of calibration was verified at least up to concentrations of 20 mg/l. The linear correlation coefficient  $R^2$  must be better than 0.998 ( $R > 0.999$ ).

### 7.2 Limits of Detection and Quantification

The limit of detection (LOD) and limit of quantification (LOQ) depends on the type of device used. Therefore, each laboratory is required to determine these values themselves.

These values shall be estimated according to the IUPAC procedure by at least 10 times measurement of a sample with a known low concentration and multiplying the standard deviation by 3 and 10, respectively. The values in Table 3 are **indicative values** that can be achieved with both column setups and a modern MSD (4.8).

	without ISTD	with ISTD
LOD	0.01 mg/l	0.01 mg/l
LOQ	0.03 mg/l	0.04 mg/l

Table 3. LOD / LOQ

The usage of the ISTD has no significant influence on the LOD and LOQ.

### 7.3 Robustness

The method is robust. No significant differences in retention times and concentrations of control samples were observed over a period of 12 months.

**Special attention should be paid to the split-vent line and trap, as gas oil will condense there. It should be cleaned or replaced regularly. Ensure that the ambient temperature does not change significantly during measurements.**

### 7.4 Specificity and selectivity

The method is specific and selective. The relevant components are baseline separated in the SIM chromatogram. The peaks of BPE and d5-BPE are not disturbed by accompanying substances such as biodiesel, red dyes, Solvent Yellow 124 or base oils in designer fuels.

### 7.5 Recovery

The recovery was tested with different concentration levels. The recovery was in the range of  $100 \pm 4$  %, with and without ISTD.

### 7.6 Repeatability and Reproducibility

The repeatability and reproducibility were found to be depending on the BPE concentration and can be expressed with the following linear functions where X is the mean of a duplicate determination:

	PROCEDURE A) without ISTD [mg/l]	PROCEDURE B) with ISTD [mg/l]
Repeatability (r)	<b><math>r = 0.0236 x + 0.0111</math></b>	<b><math>r = 0.0175 x + 0.0273</math></b>
Reproducibility (R)	<b><math>R = 0.1107 x + 0.0442</math></b>	<b><math>R = 0.076 x + 0.0219</math></b>
Calculated SD from Horwitz PRSD	$SD_{Horw} = 0.1075 X + 0.0331$	

Table 4. repeatability, reproducibility and linear fit on Horwitz predicted SD (PRSD)

## 7.7 Measurement Uncertainty

The measurement uncertainty is derived from ILS data in accordance with the "Handbook for Calculation of Measurement Uncertainty in Environmental Laboratories" from 15 March 2005 in conjunction with "Nordtest Report TR 537" (Handbook for Calculation of Measurement Uncertainty in Environmental Laboratories, version of 13 October 2003).

## Annexes

### Annex 1: Chromatograms

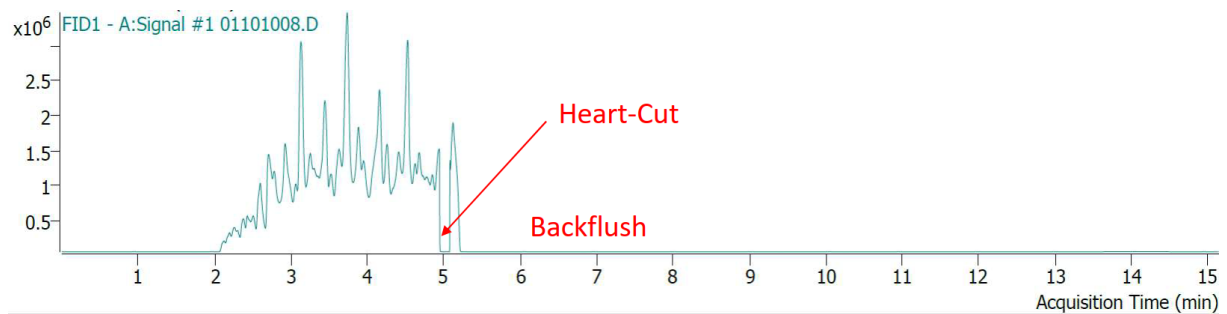

Figure 3. FID-Signal (without ISTD)

**When measuring samples with ISTD, the solvent signal of xylene dominates the FID chromatogram.**

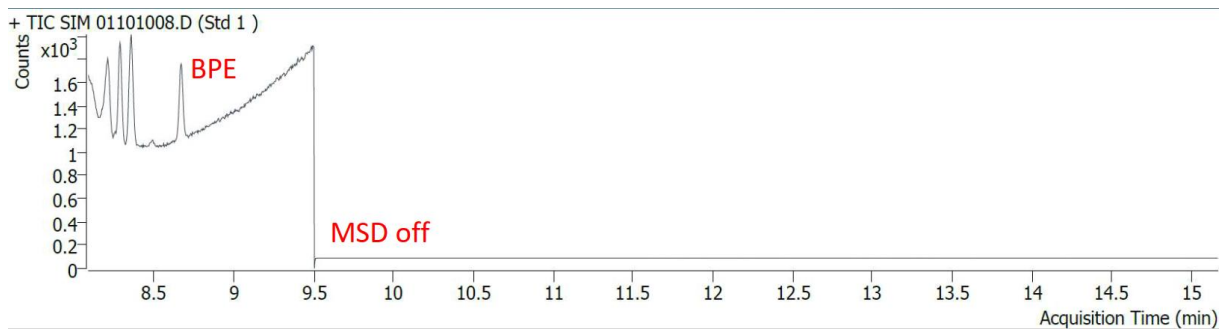

Figure 4. Total Ion Chromatogram from MSD (not used for Quantification)

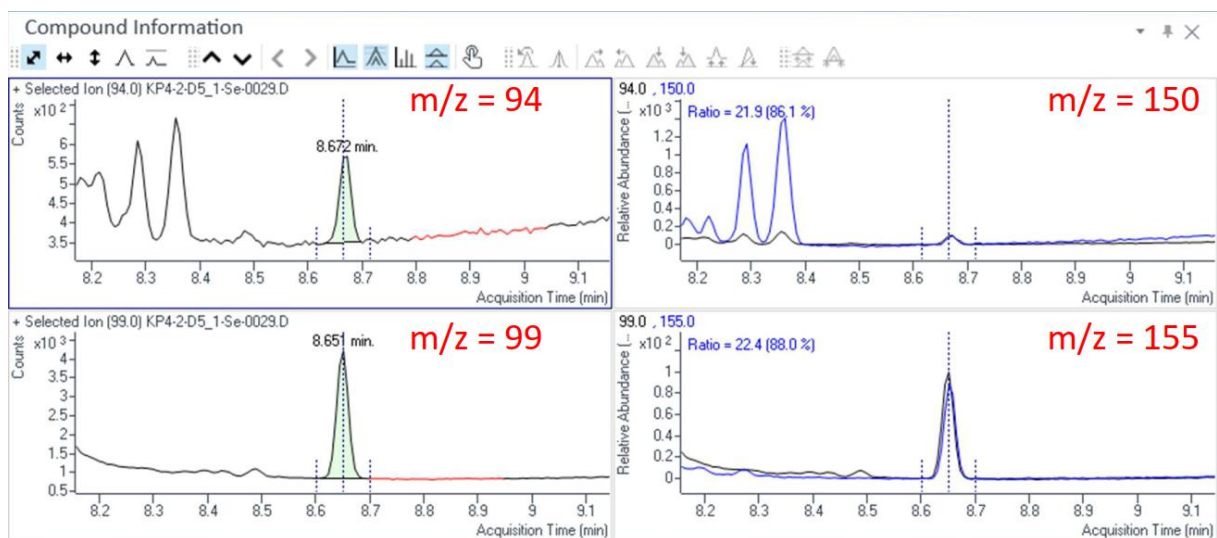

Figure 5. SIM-traces from MSD at BPE-Concentration of 0,12 mg / l (with ISTD, Split 1:100)

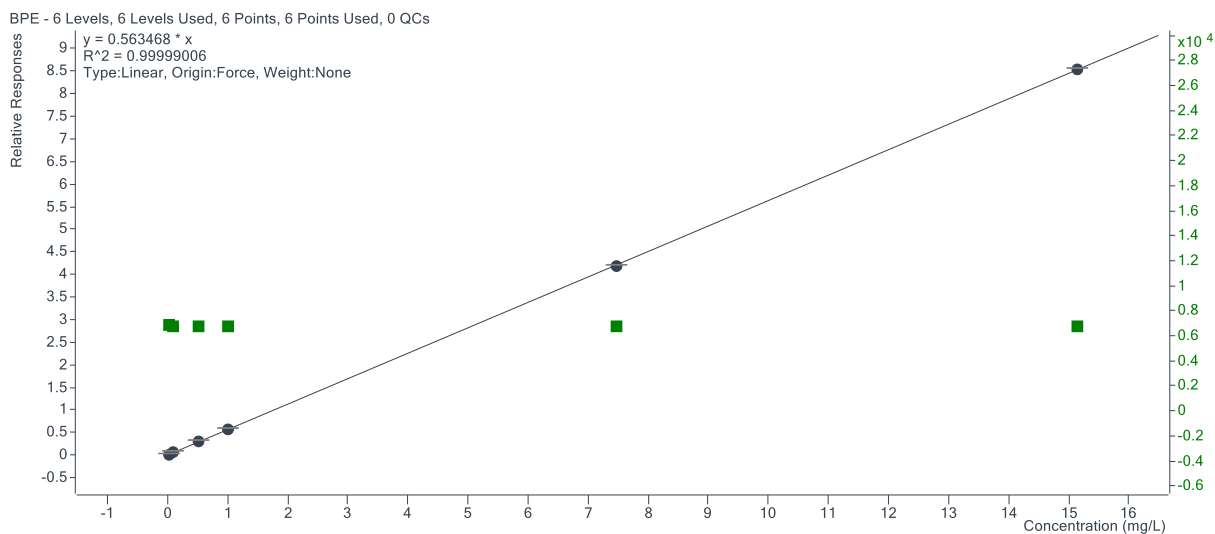

Figure 6. Typical Routine Calibration Curve with ISTD

## Annex 2: References

- [1] H.J.Kuss, S.Kromidas, VCH-Wiley, 2009, Quantification in LC and GC
- [2] Pure Appl. Chem., Vol. 74, No. 5, pp. 835-855, 2002; Harmonized Guidelines for Single Laboratory. Validation of Methods of Analysis (IUPAC Technical Report)
- [3] Pure Appl. Chem., Vol. 67, No. 10, pp. 1699-1723, 1995; Nomenclature in Evaluation of Analytical. Methods Including Detection and Quantification Capabilities (IUPAC Recommendations 1995)
- [4] Warren Smith, Daniel Saiz, Alexander Djurdjevic, The Dow Chemical Company, ACCUTRACE™ Plus. Fuel Marker reference guide, Dow Europe GmbH, March 2022.

### Annex 3: repeatability and reproducibility details

Detailed r and R observed in the CLEN inter-laboratory study on BPE determination performed in 2023.

n-butylphenyl ether	ILIADe 606 Method without internal standard			ILIADe 606 Method with internal standard		
	Robust Mean	Limit of repeatability	Limit of reproducibility	Robust Mean	Limit of repeatability	Limit of reproducibility
	$X_{pt}$	r	R	$X_{pt}$	r	R
Sample 1 (BO ≈ 0.11 mg.l <sup>-1</sup> BPE)	0.11	0.00	0.03	0.12	0.00	0.03
Sample 2 (BO ≈ 1.98 mg.l <sup>-1</sup> BPE 7.3 mg.l <sup>-1</sup> SY 124)	1.98	0.08	0.25	1.98	0.08	0.20
Sample 3 (BO ≈ 5.00 mg.l <sup>-1</sup> BPE)	4.91	0.11	0.42	4.93	0.14	0.36
Sample 4 (BO ≈ 10.00 mg.l <sup>-1</sup> BPE)	10.31	0.25	0.81	10.32	0.14	0.81
Sample 5 (BO ≈ 15.00 mg.l <sup>-1</sup> BPE)	15.01	0.31	1.46	15.22	0.25	1.15
Sample 6 (BO ≈ 0.17 mg.l <sup>-1</sup> BPE)	0.17	0.00	0.03	0.18	0.00	0.00
Sample 7 (B10 ≈ 7.00 mg.l <sup>-1</sup> BPE)	7.02	0.20	0.84	7.07	0.17	0.36
Sample 8 (BO (85%)+HVO (15%) ≈ 12.00 mg.l <sup>-1</sup> BPE)	12.19	0.36	1.62	12.28	0.28	0.78
Sample 9 (KEROSENE ≈ 10.00 mg.l <sup>-1</sup> BPE 7.3 mg.l <sup>-1</sup> SY 124)	10.07	0.28	1.68	10.11	0.20	1.09
Sample 10 (DESIGNER FUEL ≈ 8.00 mg.l <sup>-1</sup> BPE)	7.92	0.17	1.15	8.07	0.22	0.81
Sample 11 (B7 + BPE from JRC- GEEL ≈ 11.70 mg.l <sup>-1</sup> BPE)	11.65	0.28	1.20	11.69	0.25	0.87

Table 5. robust mean, repeatability and reproducibility – without and with internal standard